

Elitech®

Electric board for small and medium size cold storage



General descriptions:

ECB-1000S is widely used for the small and medium size cold storage, with the function of refrigeration, defrost, fan, light control, alarm and time display, with HACCP function, and it supports the communication of MODBUS-RTU.

Features

- Super-Big display area shows all necessary information
- Directly controls heavy loads with up to 3HP relay
- Icon LEDs status display
- Password Protection avoids accidental tampering by personnel
- Real-Time-Clock really schedules and fixes defrost time
- Defrost force function
- Energy save function at night

Technical parameters:

Power Supply: 100~240VAC, 50/60Hz Power Consumption: Less than 5W
 Temperature Measuring Range: -45°C ~99°C Accuracy: ±1°C
 Temperature Controlling Range -40°C ~90°C Resolution: 0.1°C/1°C or 1°F
 Relay Capacity of Compressor:
 Compressor 50A/240VAC Max. capacity of controlling the compressor: 3P
 Defrost 8A/220VAC
 Fan 5A/220VAC Max. capacity of controlling the fan: 500W
 Light 5A/220VAC Max. capacity of controlling the light: 300W
 Alarm 5A/220VAC
 Storage Temperature: -20°C ~75°C Work Temperature: -5°C ~60°C
 Sensor Type: NTC(10KΩ/25°C, B-3435K)

Introduction of indicator light

- ❄ Refrigeration On: Refrigerating Flash: Refrigeration delay Off: Refrigeration stop
- 🌀 Fan On: Fan working Off: Fan stop
- 💡 Light On: Light on Off: Light off
- ❄ Defrost On: Defrosting Off: Defrost stop
- 🚨 Alarm On: System alarm Off: No alarm
- 🔋 Energy conservation On: Energy saving mode of night Off: Normal mode
- 🛡 HACCP alarm symbol On: HACCP alarm Off: No alarm.

Parameter list

Temperature Setting Operation				
Temperature control Setting Point		(-50...100)°C	0	
Parameter C				
Parameter	Introduction	Range	Default Value	
1	C01	Differential	(0.1 ... 20.0)K	2.0
2	C02	Max set point limit	(C03 ... 100)°C	100.0
3	C03	Min set point limit	(-50.0 ... C02)°C	-50.0
4	C04	Min. ON-time	(0 ...15)Min	0
5	C05	Min. OFF-time	(0 ...15)Min	0
6	C06	Temperature calibration	(-12.0...12.0)°C	0.0
7	C07	Compressor On delay after Power On	(0 ...30)Min	2
8	C08	Night-Saving Function(1: On, 2: Off)	(1 ...2)	2
9	C09	Night-time start hour	(0 ...23)hour	22
10	C10	Night-time start minute	(0 ...59)min	0
11	C11	Night-time close hour	(0 ...23)hour	8
12	C12	Night-time close minute	(0 ...59)min	0
13	C13	Night set back differential	(0 ...10)K	2
Parameter A				
14	A01	High temperature alarm(tem.+C01+A01)	(0 ...30)K	10
15	A02	Low temperature alarm(tem.-A02)	(0 ...30)K	10
16	A03	Alarm differential	(1...10)K	2
17	A04	Alarm time delay	(0 ...99)min	30
18	A05	Alarm time delay after defrost end and power-on	(0 ...99)min	20
19	A06	Buzzer keeps silent when alarm occurs(1: On, 2: Off)	(1 ...2)	1
20	A07	Door open alarm time delay	(0 ...99)min	30
Parameter D				
21	d01	Defrost type (1:electric heating defrosting; 2: thermal defrosting)	(1 ...2)	1
22	d02	Defrost end function (1: temperature sensor termination, 2: defrost time termination)	(1 ...2)	1
23	d03	Defrost stop temperature (if d02=1)	(0...99)°C	8
24	d04	Defrost interval time	(0 ...48)hour	6
25	d05	Max-defrost duration	(0 ...99)min	30
26		Dripping time	(0 ...20)min	2
		First defrost delay after power-on	(0 ...99)min	0

28	d08	Max-times of defrost every day (if 003=2)	(0 ...7)	0	
29	d09	Defrost sensor calibration	(-12.0...12.0)°C	0	
Parameter F					
30	F01	Fan operation function (1:Always on; 2:Parallel to compressor)	(1 ...2)	1	
31	F02	Fan operation during defrost (1:Yes; 2:No)	(1 ...2)	1	
32	F03	Fan start temperature after defrost	(-30...5)°C	5	
33	F04	Fan start-up delay after defrost	(0 ...10)min	3	
Parameter O					
34	o01	Sensor error, compressor protection time (1:On, 2:Off)	(1 ...2)	1	
35	o02	Access Password	(0 ...999)	0	
36	o03	Defrost start mode(1:by Internal timer; 2:by Real Time Clock Module)	(1 ...2)	1	
37	o04	Display decimal(1:Yes; 2:No)	(1 ...2)	1	
38	o05	Digital input definition (1:None; 2-5:Door switch)	(1 ...5)	1	
39	o06	Temperature display in °C or °F (1:°C; 2:°F)	(1 ...2)	1	
40	o07	Digital input selection (0: Normally Closed, 1: Normally Open)	(0...1)	0	
41	o08	Communication address	(1...247)	1	
Parameter T					
42	t01	1 st defrost start hour	(0 ...23)hour	0	
43	t02	1 st defrost start minute	(0 ...59)min	0	
44	t03	2 nd defrost start hour	(0 ...23)hour	0	
45	t04	2 nd defrost start minute	(0 ...59)min	0	
46	t05	3 rd defrost start hour	(0 ...23)hour	0	
47	t06	3 rd defrost start minute	(0 ...59)min	0	
48	t07	4 th defrost start hour	(0 ...23)hour	0	
49	t08	4 th defrost start minute	(0 ...59)min	0	
50	t09	5 th defrost start hour	(0 ...23)hour	0	
51	t10	5 th defrost start minute	(0 ...59)min	0	
52	t11	6 th defrost start hour	(0 ...23)hour	0	
53	t12	6 th defrost start minute	(0 ...59)min	0	
54	t13	7 th defrost start hour	(0 ...23)hour	0	
55	t14	7 th defrost start minute	(0 ...59)min	0	
Parameter H					
56	SHi	Emergency high temperature alarm output parameters : Once the temperature is greater than the upper temperature limit SHi, the controller will immediately occur an emergency high temperature HACCP alarm without any delay. The accuracy of this parameter is 0.1 °C, and alarm display depends on the setting of parameters H50.	SHH...150.0°C/°F	35	
57	SLi	Emergency low temperature alarm output parameters: Once the temperature is lower than the lower temperature limit SLi, the controller will immediately occur an emergency low temperature HACCP alarm without any delay. The accuracy of this parameter is 0.1 °C, and alarm display depends on the setting of parameters H50.	-50.0...SLH°C/°F	-35	
58	SHH	HACCP high temperature alarm parameters: When the temperature of controller is larger than the setting of this parameter, and time exceeds time set time of parameter drA, then it will occur HACCP high temperature alarm. The accuracy of this parameter is 0.1 °C, and alarm display depends on the setting of parameters H50.	SLH...150.0°C/°F	30	58
59	SLH	HACCP low temperature alarm parameters: When the temperature of controller is lower than the setting of this parameter, and time exceeds time set time of parameter drA, and then it will occur HACCP low temperature alarm. The accuracy of this parameter is 0.1 °C, and alarm display depends on the setting of parameters H50.	-50.0...SHH°C/°F	-30	59
60	drA	HACCP alarm delay	0...99min	10	60
61	drH	HACCP alarm auto reset (all clear) time setting: When the controller is powered on, and after the set time of this parameter set, HACCP alarm will be automatically reset.	0...254 hours	0	61
62	H50	HACCP alarm settings : H50 = 0, HACCP alarm is disabled ; H50 = 1, HACCP alarm function is activated, and alarm relay has no output ; H50 = 2, HACCP alarm function is activated, and alarm relay has output.	0...2	0	62

Error code display	
E1	Short-circuited room sensor
E2	Disconnected room sensor
E3	Disconnected defrost sensor
E4	Short-circuited defrost sensor
E5	High temperature alarm
E6	Low temperature alarm
E7	Door open alarm

Parameter Description

c-Temperature Control Parameters Group

C01-Differential

This is the difference between the temperature at which the cooling output is switched off and the temperature at which the output is switched on. This is an absolute value related to the set point. It switched on when temperature goes over set point temperature +C01, and is turned off when the temperature decreases to set point temperature.

C02-Max set point limit

The set point value cannot be adjusted outside the limits defined by these parameters to avoid improper set point setting by the user

C03-Min set point limit

The set point value cannot be adjusted outside the limits defined by these parameters to avoid improper set point setting by the user

C04-Min.ON-time

The value that you set is for how long the cooling is to run once it has been started

C05-Min.OFF-time (anti short cycle)

The value is the minimum time between two subsequent switches on of the output

C06- Temperature calibration

Correct of the sensor error. Display temperature equal to measuring temperature of the actual value and the numerical C06.

C07-Compressor On delay after Power On

This value is designed for avoiding cooling output is switched on immediately when controller gets power, it should be power on after C07

C08-Night-Saving Function

This parameter determines the Night-Saving function on or not

C09-Night-time start hour

This value determines the time in Hour for the beginning of night-time

C10-Night-time start minute

This value determines the time in Minute for the beginning of night-time

C11-Night-time close hour

This value determines the time in Hour for the end of night-time

C12-Night-time close minute

This value determines the time in Minute for the end of night-time

C13-Night set back differential

This value is designed to raise the temperature setting during night-time period in order to save energy

A-Alarm Parameter Group

A01-High temperature alarm

High temperature alarm value relative to set point

E.g. If your set point is at 4, differential C01=2, and A01=5, the alarm will be triggered at 11

A02-Low temperature alarm

Low temperature alarm value relative to set point

E.g. If your set point is at 4, and A02=3, it will be triggered at 1 and cancel at 4

A03-Alarm differential

Useful to avoid alarm oscillation

Example: Set point=4, C01=2, A01=6, A03=2; In this case when the cold room temperature exceeds 4+C01+A01 = 4+2+6=12 for a time greater than parameter A04 the alarm is activated when temperature drops below 4+C01 +A01-A0 = 4+2+6-2=10, the alarm is reset

A04-Alarm time delay

Delay between the detection of the temperature alarm and the activation of the alarm sequences. This is useful to prevent temporary conditions from causing an alarm

A05-Alarm time delay after defrost end and power-on

Time the controller should automatically ignore the temperature alarm condition after defrost end and power-on

A06-Buzzer keeps silent when alarm occurs

You can select audible alarm by this parameter

A07-Door open alarm time delay (if 006=2)

Delay between the detection of the door opens and the activation of the alarm sequences. This is very useful to prevent cold room losing efficiency if the door is not closed completely

d-Defrost Parameter Group

d01-Defrost type

Select the type of your installation and the way defrost is performed

1:electric heating defrosting; 2: thermal defrosting)

d02-Defrost end function

Select the defrost termination type by temperature or by time

d03-Defrost stop temperature

This parameter determines the achieve temperature to stop defrost

d04-Defrost interval time

This is the time between two subsequent defrost cycles. This timer will initiate every defrost cycle

d05-Max-defrost duration

The defrost cycle will stop after this time even if the defrost end temperature has not been reached

d06-Dripping time

After defrost is terminated the compressor or cooling valve is stopped to allow the evaporator to drip

d07-First defrost delay after power-on

This parameter allows to delay a defrost cycle after power-on. This will prevent a cycle from occurring before the cold room has reached its operations temperature

d08-Max-times of defrost every day(if 003=2)

This parameter defines how many times is needed for fixed defrost by RTC each day

d09-Defrost sensor calibration

Correct the sensor error. Display temperature equal to measuring temperature of the actual value plus d09 value

F-Fan Control Parameter Group

F01-Fan operation function

This parameter determines the fan work mode

F02-Fan operation during defrost

This parameter determines the fan work or not during defrosts

F03-Fan start temperature after defrost

This parameter determines the temperature when the fan start work after defrost

F04-Fan start-up delay after defrost

This parameter determines the delay time of fan then it work after defrost

o-Other Parameter Group

o01- Sensor error, compressor protection time

This parameter determines when the sensor error occurs, compressor turns on/off with proportional time

o02-Access Password

This allows to protect all the setting in the controller by an access code

o03-Defrost start mode

This parameter allows you to choose defrost start mode

o04-Display decimal

This parameter allows you to choose temperature display with or without decimal

o05-Digital input definition

None or Door Switch

When door opens-evaporator's fan stops automatically

When door closes-evaporator's fan runs automatically

o06-Temperature display in °C or °F

This parameter determines displayed temperature in °C or °F

t-Time schedule of defrost by Real Time Clock

t01-1st defrost start hour

This value determines the time in Hour of the 1st defrost generation every day

t02-1st defrost start minute

This value determines the time in Minute of the 1st defrost generation every day

t03-2nd defrost start hour

This value determines the time in Hour of the 2nd defrost generation every day

t04-2nd defrost start Minute

This value determines the time in Minute of the 2nd defrost generation every day

t05-3rd defrost start Hour

This value determines the time in Hour of the 3rd defrost generation every day

t06-3rd defrost start Minute

This value determines the time in Minute of the 3rd defrost generation every day

t07-4th defrost start Hour

This value determines the time in Hour of the 4th defrost generation every day

t08-4th defrost start Minute

This value determines the time in Minute of the 4th defrost generation every day

t09-5th defrost start Hour

This value determines the time in Hour of the 5th defrost generation every day

t10-5th defrost start Minute

This value determines the time in Minute of the 5th defrost generation every day

t11-6th defrost start Hour

This value determines the time in Hour of the 6th defrost generation every day

t12-6th defrost start Minute

This value determines the time in Minute of the 6th defrost generation every day

t13-7th defrost start Hour

This value determines the time in Hour of the 7th defrost generation every day

t14-7th defrost start Minute

This value determines the time in Minute of the 7th defrost generation every day

Configuration Chart

Set point: (no need password)

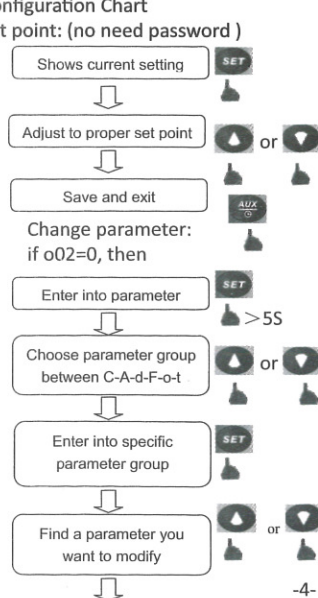

Forced defrost :(no need password)

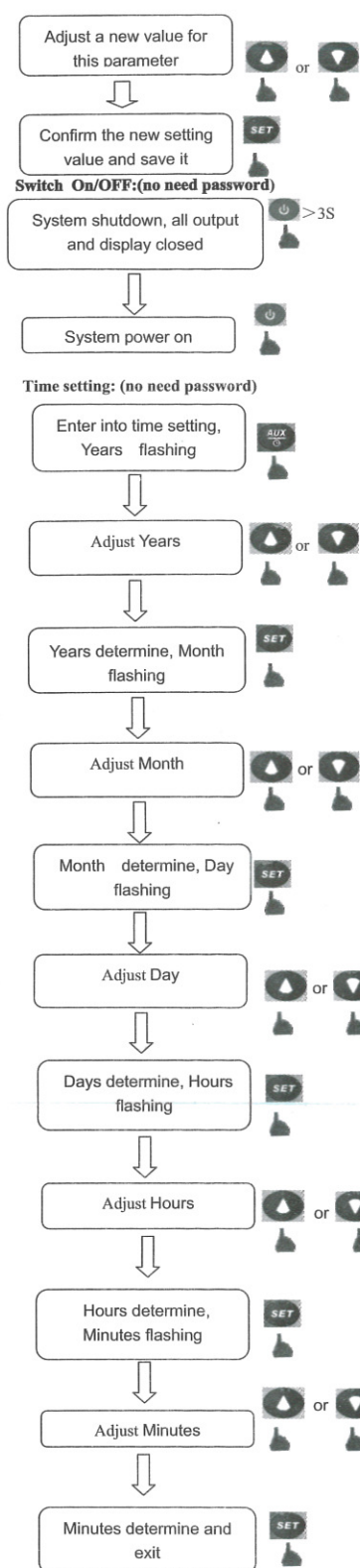
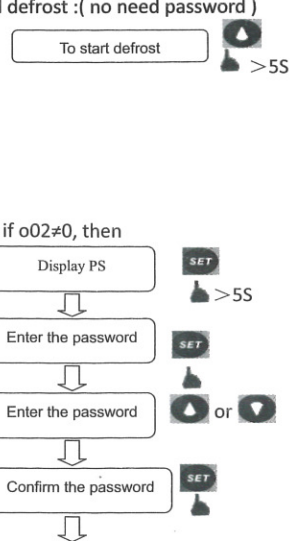

Password correctly into the system parameter setting, password mistake returns, Enter the password

Light control: (no need password)

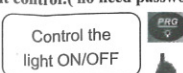

Illustrate:

When parameters Settings, this button can be used as return or

View Defrost temperature:

Press then release, enter View defrost temperature, after four seconds, exit to the normal temperature display status, automatically

When it displays "01:PF", press SET key, the upper digital tube display "SPF", and the lower digital tube display power failure time (eg 12:55), press ▲ or ▼ key to switch between alarm time and alarm date, and in the lower digital tube it switches between alarm time (eg 12:55) and alarm date (eg for June 20 , display 06:20) .

When digital tube displays "ALr", "tP", press SET key to enter the viewing of alarm maximum temperature and alarm minimum temperature, and in the upper digital tube display "AtP", and in the lower digital tube display "01: Ht" (maximum temperature), press ▲ or ▼ key to switch between "01: Ht" and "02: Lt" (minimum temperature). When it displays "01: Ht" , press SET key, in the upper digital tube display the maximum temperature and in the lower digital tube display alarm time, press ▲ key or ▼ key to switch between alarm time and date of maximum temperature (Date format: for June 20 , display 06:20). Press AUX key to exit to the previous menu, and press AUX key again and again until it exits from viewing status.

Alarm reset: When the system running time is longer than drH, the system automatically clears all HACCP alarm.

Note: When the parameter o05=2 , if the door switch is open, there is no effect on the compresses, and the fan stopped, light is on, the lighting is controlled by the light control button; if o05=3, light is only controlled by the door switch, not controlled by the lighting control button, the compressor and fan will not be affected ; if o05 = 4, when door is open , the compressor and the fan stops, the light is controlled by the door switch not by the light button control; If o05 = 5, when the door opens, it has no effect on the compressor or the fan, the alarm relay picks up and the buzzer beeps; when the door is closed, the alarm relay is switched off and the sound of buzzer is muted; lighting is controlled by the lighting button.

MODBUS-RTU RS485 communication
Adopt MODBUS-RTU communication slave mode, support MODBUS-RTU command 03 (Read holding Registers), 06 (write single register)

Wiring diagram

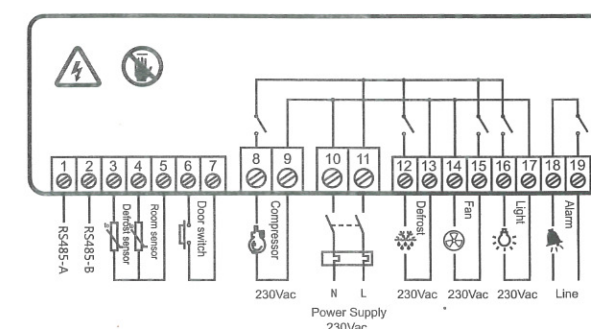

HACCP alarm view and reset

When H50 ≠ 0, and HACCP alarm occurs, press ▲ key , it displays "ALr" in the upper digital tube of controller, and displays "ACP" (high and low temperature alarm) in the lower digital tube of controller. At this time press ▲ key or ▼ key to switch between alarm code among "PF" (power failure alarm), "PT" (maximum and minimum temperature) and "ACP".

If there is high/low temperature alarm, when it displays "ACP", press SET key, it displays "AHC" in the upper digital tube and it displays "01: Ht" in the lower digital tube. Then press ▲ key or ▼ key to page up/down the alarm sequence and type (eg 02: Lt, or 02: Ht , etc.) ;

When display "01: Ht", press SET key, the upper digital tube display "STA", and the lower digital tube display alarm time (eg 12:55), press ▲ key, display date (eg for June 20 , it displays 06:20) Press ▲ or ▼ key to switch between alarm time and date, press AUX key to exit from alarm time viewing , the upper digital tube display "AHC", and lower digital tube display "01: Ht", then press AUX key again, the system exits to the previous menu , and the upper digital tube display "ALr", the lower digital tube display "ACP";

When in the upper digital tube display "ALr", and lower digital tube display "PF", if there has power failure alarm, press SET key, the upper digital tube display "AnC", and lower digital tube display "01 : PF ", then press ▲ or ▼ key to switch between "02: Ht " and "03Ht " (if exist) ;