



**Making Your Job More Enjoyable**

**Vacuum Pump**

**VRP-15D**



**VALUE** • Quality Assurance

**NAVTEK™**  
High-end Series

# TABLE OF CONTENTS

---

---

INTRODUCTION AND TECHNICAL INFORMATION .....	01
DC INVERTER DRIVE VACUUM PUMPS .....	01
APPLICATION .....	01
SPECIAL FEATURES .....	01
PREPARATION PRIOR TO USING VACUUM PUMP .....	02
SAFETY WARNINGS .....	02
USE GUIDE .....	03
MAINTENANCE .....	04
REQUIREMENT FOR WARRANTY COVERAGE .....	04
TROUBLESHOOTING .....	05
EXPLODED VIEW .....	06
REPAIR PARTS LIST .....	07
DIMENSION .....	08

## INTRODUCTION AND TECHNICAL INFORMATION

In order to make it easier to understand the components of the vacuum pump, please see the picture below.



## DC INVERTER DRIVE VACUUM PUMPS

Model	√RP-15D
Flow Rate	15 CFM 420L/min
Ultimate Vacuum	5 micron
Motor Power	3/4HP
Oil Capacity	880ml
Dimensions	414×152×310mm
Weight	14.5Kg
Inlet Port	1/4"×3/8"×1/2" Flare

## APPLICATION

NAVTEK inverter drive dual-stage rotary vane vacuum pumps are used to remove air, moisture, and other non-condensables from sealed HVACR systems. The products can be used for evacuation of HVACR repair and new installations, with refrigerants including CFC, HFC, and HCEF, such as R-12, R-22, R-410A, R-404A, R-32, R-134A, 1234yf, etc.

## SPECIAL FEATURES

- Integrated vacuum gauge/pump structure, high precision, for deep ultimate vacuum level.
- Forced oil lubrication ensures vane sealing, cooling and high reliability.
- Large and easy to see oil-level window design help prevent oil supply shortage.
- Non-sparking design, suitable for R-32, 1234yf refrigerants.

## PREPARATION PRIOR TO USING VACUUM PUMP

1. Verify the power supply being used, to match the voltage on the nameplate.
2. Ensure that the pump is switched off prior to connecting to the power source.
3. Check for proper oil level, or change if needed.
4. Remove the oil fill cap, filling oil to the level in between the two oil sight glass lines, as shown in the drawing below. For specific pump oil volume, please see the technical specification table.

Note: In order to prevent pump oil from spilling out, please add oil slowly.

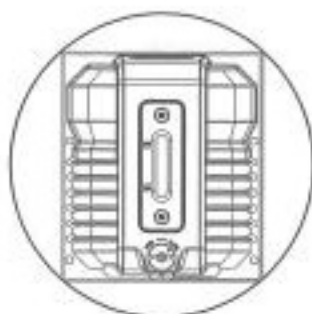

Switch on the power and the pump will begin to operate. After running for approximately one minute, check the oil level. If the oil level is too low, switch off the machine and add the required extra oil. Reinstall the oil fill cap.

Note: While the pump is operating, the oil level should be in between the two oil position lines. If the oil level is too low, it will reduce the performance and could damage the pump vanes. If the oil level is too high, it could cause oil to discharge through the pump exhaust.

## SAFETY WARNINGS

Note: In order to avoid personal injury, please carefully read and follow the instructions in this user manual and the user guide of the pump.

**NAVTEK VACUUM PUMPS ARE NOT ALLOWED TO BE USED FOR A3 OR FLAMMABLE REFRIGERANTS.**

1. NEVER CONNECT A VACUUM PUMP TO A PRESSURIZED SYSTEM. Always check to make sure that system and piping pressure is NOT ABOVE ATMOSPHERIC PRESSURE.
2. When handling refrigerants, please wear an eye-protection such as safety glasses or goggles.
3. Avoid direct physical contact with refrigerants, you will get burned.
4. When connecting the power source, all equipments must be grounded in order to prevent electrical hazards.
5. When the pump is in operation, the enclosure surfaces will be hot. Do not touch the oil box or the motor case. Allow adequate ventilation space for heat dissipation.
6. When using R-32, 1234yf or other flammable refrigerants, use an explosion proof electrical outlet.
7. Keep pump dry and away from water, mud, and dirt at all times.
8. Operating pump with intake fittings open to the atmosphere must not exceed 3 minutes.

9. Ambient temperature range for pump use is 30 to 104°F (-1°C~40°C). The pump can be used in lower ambient conditions, if warmed up inside first and run for no more than 1 minute to warm the oil prior to system evacuation.
10. The pump requires 115V±10% power, and the power outlet must be grounded.
11. Prior to connecting the vacuum pump to an A/C-R system, please use proper methods to remove refrigerant from a pressurized system. Note that pumping refrigerants under high-pressure conditions will damage the pump, and refrigerant must be removed using a recovery machine designed for that purpose.

## USE GUIDE

1. When using the vacuum pump, remove the inlet protection cap from the desired (1/4", 3/8", or 1/2") connecting port, as shown in the diagram above, and connect the pump to the system or piping to be evacuated.

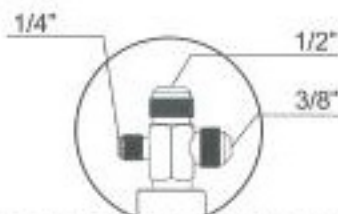

- Use shortest hoses possible for faster and more thorough evacuation.
2. Inspect the hose inlet connection, as well as all connecting hoses for proper seal. There must be no leakage or it will be impossible to draw the required deep vacuum level.
  3. At the beginning of the evacuation process, open the GAS BALLAST, and once the vacuum gauge reaches 2000 microns, retighten to achieve desired vacuum level.
  4. After evacuation is completed, shut down the pump and close the system access valves.
  5. Turn off the power switch on the pump and disconnect power.
  6. Remove the evacuation hoses.
  7. Close the air entry cap and the air exhaust cap tightly (with the exception of models without air exhaust cap), to prevent dirt or particulates from entering the pump.

### Note:

1. Always evacuate systems in conjunction with a micron vacuum gauge, such as the NAVTEK NMV1, if using the standard inverter drive pump. Micron vacuum gauges precisely measure and display system evacuation during the entire process, giving you a comprehensive view of the sealed system internal evacuation condition.
2. Please pay attention to any changes in the oil level during pump operation. If the oil level falls below the center line, immediately add more vacuum pump oil to avoid damage to the pump.
3. Vacuum pump and oil must be above 30°F.

## MAINTENANCE

1. Vacuum pump oil has three major functions: pump lubricant, pump cooling, and pump sealant. During the evacuation process, the pump oil will absorb moisture being pulled from the system, causing it to be less effective as a lubricant and pump vane seal, extending evacuation time and possibly allowing the pump to overheat. We recommend that the oil be changed just before evacuating each A/C-R system to insure the pump oil is in a clean condition as this is the key factor in determining if the pump can achieve the required vacuum levels. In order to maintain the optimum operation of the pump, we recommend that you use NAVTEK vacuum pump oil. This oil is made using a unique process and can maintain proper viscosity during normal operation and temperatures, and it's also helpful for cold starts. Should the NAVTEK oil not be available, reputable brands of special-purpose vacuum pump oil may be used.

**Note:** Should the pump oil become opaque, dirty, or full of moisture, promptly change oil. This will greatly speed up evacuation, especially when there is a lot of moisture in system piping from having been left open to the atmosphere for an extended period of time.

Oil change procedure:

1. To ensure that the pump and oil are warm, run pump for approximately one minute prior to changing oil. Do not run longer than this, as it may be possible to damage the pump.
2. While the pump is running, open one inlet port and allow oil to drain out of the pump. After turning off pump, open the oil drain plug, and drain used oil into an appropriate vessel and dispose of properly.
3. As oil stops draining, tip the pump to drain any remaining oil in the bottom of the pump.
4. Close oil drain valve.
5. Remove oil fill cap, pour in new oil until the oil is at the proper level in the sight glass (the same procedure prior to using the pump above).

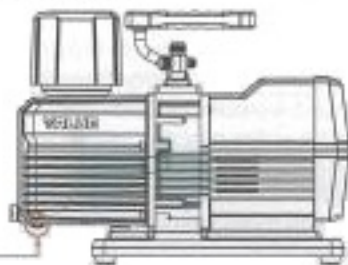

Oil drains out from here

## REQUIREMENTS FOR WARRANTY COVERAGE

Product warranty is provided for product quality problems for two years from date of sale. For warranty to be valid, the following conditions must be met:

1. Products issues due to manufacturing defects confirmed by qualified agents.
2. Products which have not been maintained or dismantled by unauthorized parties.
3. Products that have been used in accordance with the User Manual. All maintenance services shall be performed during the warranty period.

**Statement:** Other than repairing the product defective, the manufacturer of this product will not be liable for any other costs, such as time spent in fixing the issue, refrigerant consumption, refrigerant disposal costs, as well as unauthorized transportation and labor costs.

## TROUBLESHOOTING

Malfunction	Possible Cause	Remedy
Low Vacuum	1. Secondary air inlet connection cap loose on the air inlet port.	Tighten the cap.
	2. Damaged rubber ring inside the secondary air inlet connection cap.	Replace the rubber ring.
	3. The volume of oil is insufficient.	Add oil to the center line of the oil display.
	4. Pump oil becomes opaque or absorbed too many impurities.	Replace with new oil.
	5. The pump's oil entry hole is clogged or the oil supply is insufficient.	Clean the oil entry hole, clean the oil filter.
	6. The pump connecting hoses, manifold or system has a leak.	Inspect the connecting hose gaskets and system, repair leaks.
	7. The pump selection is wrong.	Check the size of the container to be evacuated, recalculate and select an appropriate pump model.
	8. The pump has been used for too long, damage and wear to components caused increased gaps between parts.	Inspect and repair, or replace the pump.
Oil leak	1. Damaged oil seal.	Replace the oil seal.
	2. Loose or damaged oil box connections.	Tighten the connecting screws, replace O-rings.
Oil spray	1. Excessive oil volume.	Remove oil until the oil position line is reached.
	2. Inlet port pressure is excessively high for a long period.	Select an appropriate pump, increase the pumping speed.
Start-up problems	1. Oil temperature is too low.	Exposed the air entry hole to the external atmosphere, and remove the oil fume filtration device. Use a screwdriver to turn the engine axle in an anti-clockwise direction.
	2. Motor, power source or circuit board malfunctions.	Inspect and repair.
	3. Foreign objects entered the pump.	Inspect and remove.
	4. Voltage supply is excessively low or high.	Inspect the power source voltage.
	5. Overload trips	After overload trip occurs, switch kept On. Remove the power plug, wait for approximately 30 seconds before inspecting and repairing.

### Notes:

1. The pump is inverter driven and the motor has over-current / overload protection, please troubleshoot after overload resets.
2. If the above methods cannot resolve your problems, please contact your nearest distributor or take the pump to a repair center. We will do our best to provide you with a quick turnaround to keep you working.

EXPLODED VIEW

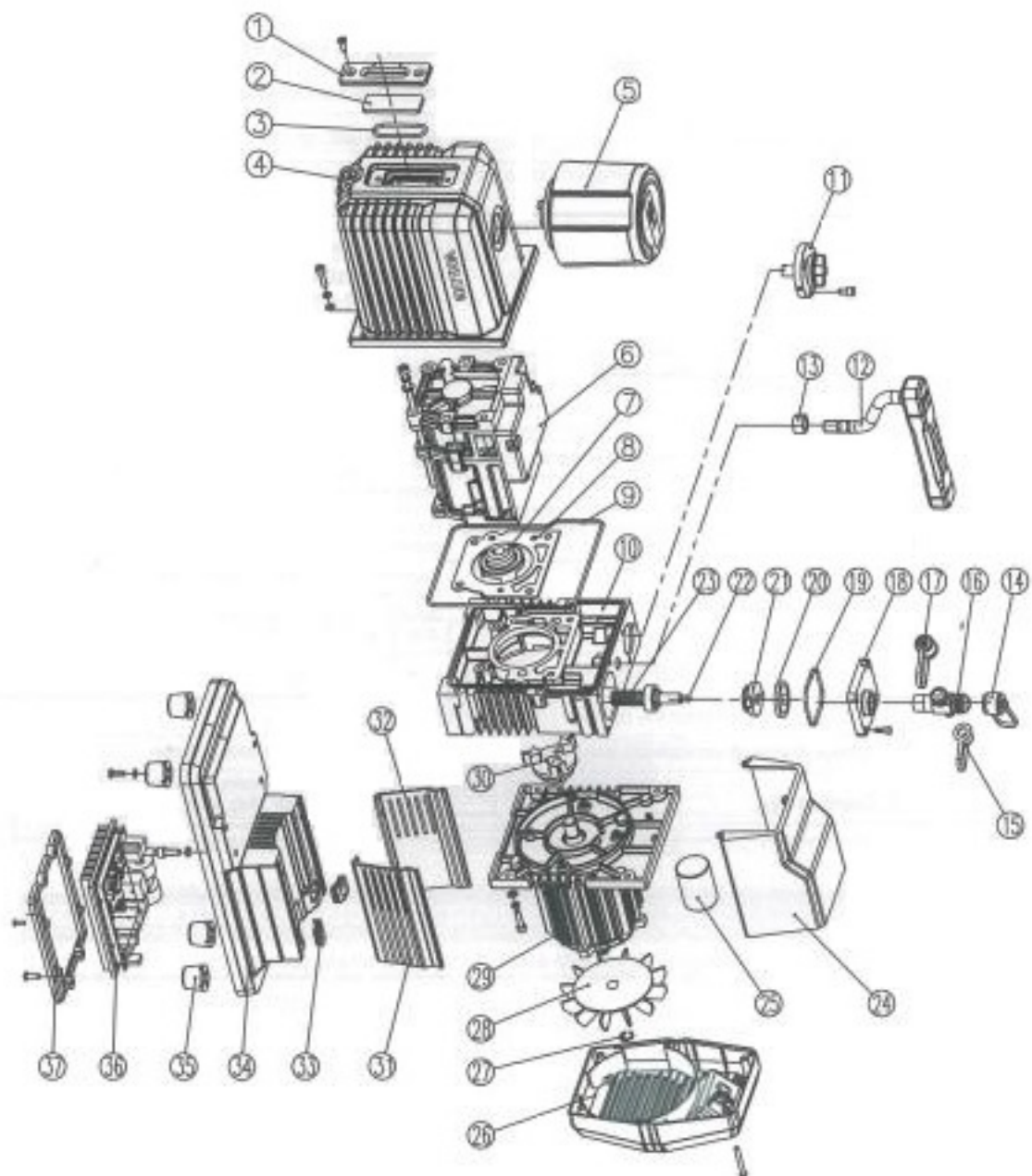



## REPAIR PARTS LIST

Ref No.	Part No.	Part Name
1	320180205	Oil Lens Cover
2	320170203	Oil Lens
3	320160204 *	O-ring of Oil Lens
4	N/A	Oil Housing
5	N/A	Exhaust Filter and Noise Reducer
6	N/A	Pump Body
7	320040211	Coupling
8	322450101	Gasket
9	300310080	O-ring of Oil Housing
10	320030207	Trestle
11	N/A	Gas Ballast Assy
12	310291801	Handle
13	300210401	Nut
14	310640901	1/2" Cap
15	310640701	1/4" Cap
16	310911061	Inlet Port
17	310640801	3/8" Cap
18	320350044	Base of Inlet Port
19	300310125	O-ring of Inlet Port
20	320510101	Anti suckback valve plate
21	320530201	Anti suckback valve cap
22	320660101	Anti suckback piston assy
23	320110203	Anti suckback spring
24	310333201	Top Cover
25	310493801	Capacitor
26	N/A	Rear Cover Assy
27	300150601	Elastic Collar
28	310190103	Fan
29	321490201	DC Motor Assy
30	320040111	Coupling
31	310173601	Guard Board I
32	310173602	Guard Board II
33	310440801	Sheath
34	320011104	Base Plate
35	310260301	Rubber Feet
36	311510607	Controller Assy
37	321180701	Cover Plate

**DIMENSION**

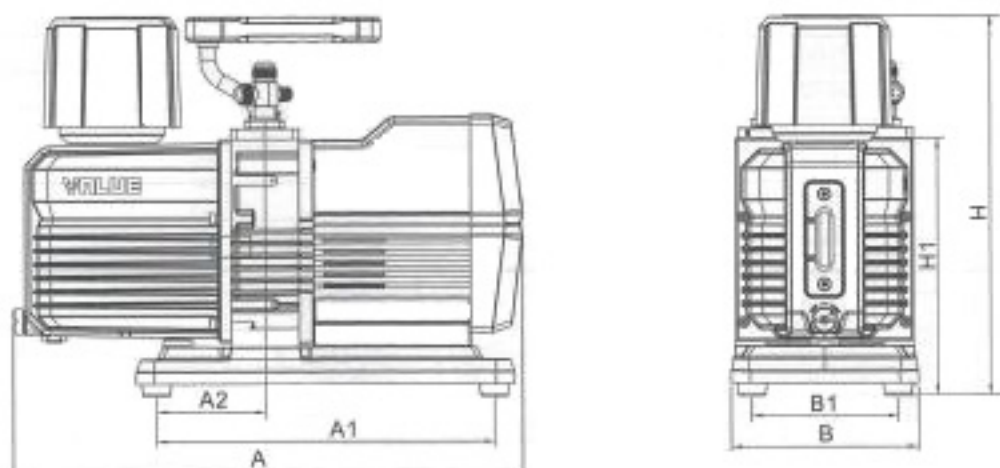

Unit: mm

Model	A	A1	A2	B	B1	H	H1
VRP-15D	414	274	88	152	119	310	208





**VALUE Mechanical & Electrical Products CO., LTD**

Add: Jiulong Avenue, Western Industrial District, Wenling, Zhejiang, China

Tel: +86-576-86191959

Fax: +86-576-86191957

Email: [value@worldvalue.cn](mailto:value@worldvalue.cn)

[www.worldvalue.cn](http://www.worldvalue.cn)